

IDB-HCS08GB Evaluation Board For Freescale MC9S08GB60

User's Manual (Rev. 3.0)

1. Introduction

Overview

The IDB-HCS08GB Evaluation Board demonstrates the capabilities of the 64-pin MC9S08GB60 device. The IDB-HCS08GB Evaluation Board can be used as a standalone application or with an emulator system, such as inDART-HCS08, through a standard BDM connection.

Board Features

The IDB-HCS08GB Evaluation Board has the following hardware features:

1. A "MCU" section containing a MC9S08GB60 microcontroller (in LQFP64 package).
2. An "ATD REFERENCE" section which allows you to define the high and low threshold for the MCU internal A/D converter.
3. An "OSC" section containing a 8-MHz oscillator, together with a jumper for the oscillator source selection.



Copyright © 2006 SofTec Microsystems®
DC01018

SofTec Microsystems
E-mail (general information): info@softecmicro.com
E-mail (marketing department): marketing@softecmicro.com
E-mail (technical support): support@softecmicro.com
Web: <http://www.softecmicro.com>

Important

SofTec Microsystems reserves the right to make improvements to its products, their documentation and software routines, without notice. Information in this manual is intended to be accurate and reliable. However, SofTec Microsystems assumes no responsibility for its use, nor for any infringements of rights of third parties which may result from its use.

SOFTEC MICROSYSTEMS WILL NOT BE LIABLE FOR DAMAGES RESULTING FROM LOSS OF DATA, PROFITS, USE OF PRODUCTS, OR INCIDENTAL OR CONSEQUENTIAL DAMAGES, EVEN IF ADVISED OF THE POSSIBILITY THEREOF.

Trademarks

SofTec Microsystems is a registered trademark of SofTec Microsystems, Spa.

Freescale™ and the Freescale logo are trademarks of Freescale Semiconductor, Inc.

Microsoft and Windows are trademarks or registered trademarks of Microsoft Corporation.

PC is a registered trademark of International Business Machines Corporation.

Other products and company names listed are trademarks or trade names of their respective companies.

4. A "BDM" section, containing a standard BDM connector for in-circuit debugging/programming.
5. A "POWER SUPPLY" section containing a connector for a 9-12 V, 200 mA (unregulated) power supply plus an auxiliary connector for a 3.3 V (max., regulated) power supply, together with a jumper to select the power supply source;
6. An "INPUTS" section containing:
 - Two push-buttons, connected to RESET and PTC5;
 - Eight general-purpose DIP-switched connected to Port A;
 - Eight jumpers to connect/disconnect each of the eight DIP-switches to/from their respective Port A pins;
 - A potentiometer, together with a jumper to connect/disconnect it to/from PTB0.
7. An "OUTPUTS" section containing eight high-efficiency (low-current) LEDs connected to Port F, together with eight jumpers to connect/disconnect each of the eight LEDs to/from their respective Port F pins.
8. A "SIGNAL PINS" section containing a connector area to access the I/O pins of the microcontroller for expansion prototyping.
9. A "PROTOTYPE AREA" section.

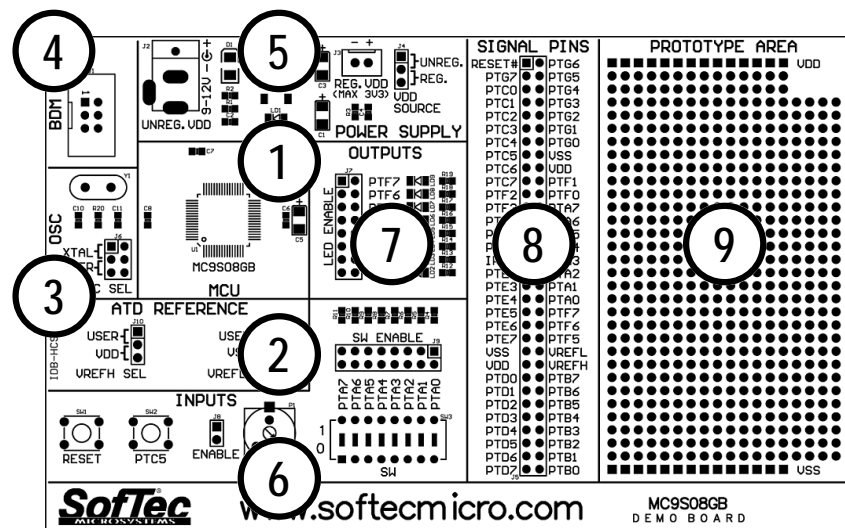

The IDB-HCS08GB Demo Board

Recommended Reading

- Freescale MC9S08GB datasheet;
- Freescale HCS08 Family Reference Manual;
- inDART-HCS08 User's Manual.

2. Getting Started

Overview

The IDB-HCS08GB Evaluation Board may be used as a standalone application or with a BDM-based emulator/programmer (host mode).

Powering Up the Board

The IDB-HCS08GB Evaluation Board can be powered either via the "UNREG. VDD" connector (J2) or the "REG. VDD" connector (J3).

- The "UNREG. VDD" connector accepts 9-12 V DC, 200 mA wall plug-in power supply with a 2.1 mm pin and sleeve plug with positive in the center and sleeve as ground. When powering the board through this connector, make sure the "VDD SOURCE" jumper (J4) selects the "UNREG." position. The "UNREG. VDD" voltage is internally regulated to 3 V DC.
- The "REG. VDD" connector accepts 3.3 V DC (max.). When powering the board through this connector, make sure the "VDD SOURCE" jumper (J4) selects the "REG." position. The "REG. VDD" voltage directly powers the microcontroller and the rest of the board. The "REG. VDD" connector has been designed to be used together with inDART-HCS08.

Running the Example

The IDB-HCS08GB Evaluation Board can be used in conjunction with a BDM-based emulator/programmer, such as SofTec Microsystems inDART-HCS08 In-Circuit Debugger/Programmer.

If you use the evaluation board with SofTec Microsystems inDART-HCS08, a sample application is available, where the program execution is controlled by the host PC. You can use the PC, additionally, to debug the application by, for example, execute the program step by step and watching how the microcontroller registers vary, by using the Metrowerks CodeWarrior HC(S)08 IDE provided with inDART-HCS08. Please refer to the inDART-HCS08 user's manual for a step-by-step tutorial.

3. Hardware Reference

"OSC" Section

	<p>J6 – OSC SEL</p> <p>1-3, 2-4 On-board oscillator (default)</p> <p>3-5, 4-6 User-provided clock (to EXTAL pin)</p>
--	---

“POWER SUPPLY” Section

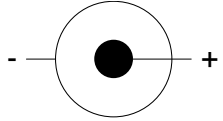
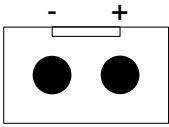
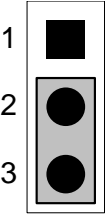
	<p>J2 – UNREG. VDD</p> <p>Input: 9-12 V DC (200 mA max.) Internally regulated to 3 V DC.</p>
	<p>J3 – REG. VDD</p> <p>Input: 3.3 V DC (max.) No internal regulator used.</p>
	<p>J4 – VDD SOURCE</p> <p>1-2 Use the “UNREG. VDD” connector (J2) (default)</p> <p>2-3 Use the “REG. VDD” connector (J3) (default)</p>

“BDM” Section

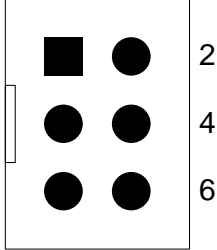
	<p>J1 – STANDARD BDM CONNECTOR</p> <p>1 BKGD 2 VSS 3 N.C. 4 RESET# 5 N.C. 6 VDD</p>
---	--

“ATD REFERENCE” Section

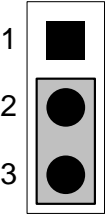

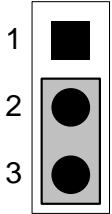

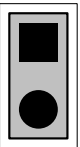
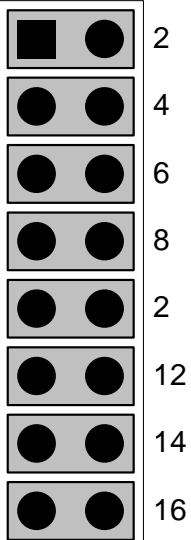

	<p>J10 – VREFH SEL</p> <p>1-2 VREFH pin N.C. (available for user applications on the “SIGNAL PINS” section)</p> <p>2-3 VREFH pin connected to VDD (default)</p>
---	--

	<p>J11 – VREFL SEL</p> <p>1-2 VREFL pin N.C. (available for user applications on the “SIGNAL PINS” section)</p> <p>2-3 VREFL pin connected to VSS (default)</p>
---	---

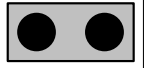
“INPUTS” Section

	<p>J8 – POTENTIOMETER ENABLE</p> <p>Installed: Potentiometer connected to PTB0 pin (default)</p> <p>Not Installed: PTB0 pin N.C. (available for user applications on the “SIGNAL PINS” section)</p>
	<p>J9 – SW ENABLE</p> <p>Each jumper, when installed, connects a DIP-switch to the respective PTAx pin.</p> <p>When a jumper is not installed, the respective PTAx pin is N.C. (available for user applications on the “SIGNAL PINS” section)</p>

“OUTPUTS” Section

1		2	J7 – LED ENABLE Each jumper, when installed, connects a LED to the respective PTFx pin. When a jumper is not installed, the respective PTFx pin is N.C. (available for user applications on the “SIGNAL PINS” section)
3		4	
5		6	
7		8	
9		2	
11		12	
13		14	
15		16	

